

R3520-10



5 AVIAN STREET, KUNDA PARK, QLD, 4556

LANDSCAPE SPOT LIGHT

RATING:

Ingress protection - IP 56.

MATERIALS:

Pressure die-cast satin brass housing.
Stainless steel screws.
High temperature seals.

GLASS:

Heat resilient, flat tempered 5mm glass.

LAMP:

MR16.
35 Watt maximum.
(lamp not included).

SOCKET:

G 4
G 5.3
G 6.35

CABLE:

2 core round, 0.75 mm².
Silicone cable.
Length - 500mm.

CABLE ENTRY:

Bottom entry.
Silicone cable.

TRANSFORMER:

Refer to transformer specification sheet.

APPLICATION:

This fitting is designed for landscape lighting projects, including highlighting trees and shrubs. The hood provides a beam of light, which can be directed to illuminate a specific area.

R3520

LANDSCAPE LIGHT WITH HOOD

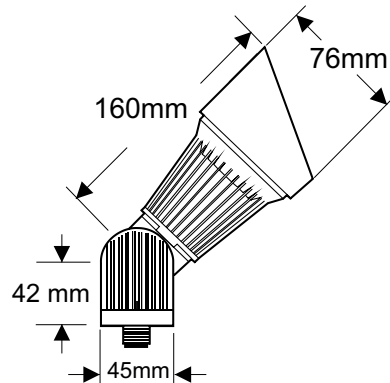

R3510 - LANDSCAPE LIGHT

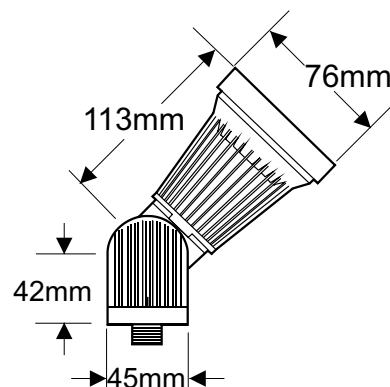

Sizes in millimetres



E1990

EXTRA LOW VOLTAGE LANDSCAPE LIGHTING

email sales@raydz.com.au

5 AVAIN STREET, KUNDA PARK, QLD, 4556

Ph (07) 5456 4141 Fax (07) 5456 1601